

aeroPULSE

FS50

High-power femtosecond fiber laser

HAMAMATSU



High performance and rugged ultrafast fiber laser

Industrial-grade femtosecond fiber laser

The aeroPULSE FS50 is our industrial-grade femtosecond fiber laser based on our world-leading photonic crystal fiber platform.

Developed for both demanding 24/7 OEM and academic applications, the aeroPULSE FS50 delivers high unit-to-unit consistency and up-time, low cost of ownership, and ease of integration.

Designed for ease of use and equipped with dedicated software development tools, the FS50 platform can be installed and running in your application within a few hours.



aeroPULSE FS50

Applications

Neurostimulation

Semiconductor manufacturing

Through-Glass Vias (TGVs)

Thin film cutting

Diamond milling

Glass cutting and milling

Glass welding

Stent manufacturing

Medical device fabrication

Photostimulation

OPA pumping

Flexi-PCB manufacturing

Femtosecond materials processing

IC package cutting

Scribing

Reliable

Ultra-short femtosecond pulses

This high performance and rugged OEM fiber laser utilize state-of-the-art mode-locking technology to deliver ultra-short femtosecond pulses with outstanding long-term stability, superior pulse-to-pulse stability, low noise, and excellent beam pointing stability.

Developed for cutting edge applications

The aeroPULSE FS50 is designed for a diverse range of applications including thin film cutting, glass cutting, stent, and other medical devices, IC package cutting, scribing, OPA pumping and material processing.

With the introduction of programmable amplifier burst control, higher ablation rates or depths can be achieved over non-burst processing for many applications. This new feature allows for full process optimization.

As standard, the aeroPULSE FS50 is available with output powers up to 50 W at 1030 nm. With tunable pulse duration and a high range of repetition rates, the aeroPULSE FS50 is a flexible, cost-effective femtosecond laser.

Get the dual wavelength second-harmonic module

The attachable second-harmonic generation (SHG) module makes it possible to switch between 20 μ J at 515 nm and 40 μ J at 1030 nm. The wavelength is selected via software.

Maintenance-free and OEM-ready

Utilising our proprietary optoCAGE(TM) technology results in no alignment for ultimate reliability. The aeroPULSE FS50 guarantees high stability with 24/7 operation and is ideal for OEM integration.

The system configuration consists of a 19" rack-mountable control unit and a remote laser head. The complete system is water-cooled supporting the high output power performance.

aeroPULSE FS50

Support and warranty

The product is covered by a comprehensive warranty. Service options are available. For details, please enquire.

All aeroPULSE lasers are completely maintenance-free and have an expected lifetime of more than 20,000 hours.

Performance

Typical output power and pulse energy vs repetition rate

aeroPULSE
FS50

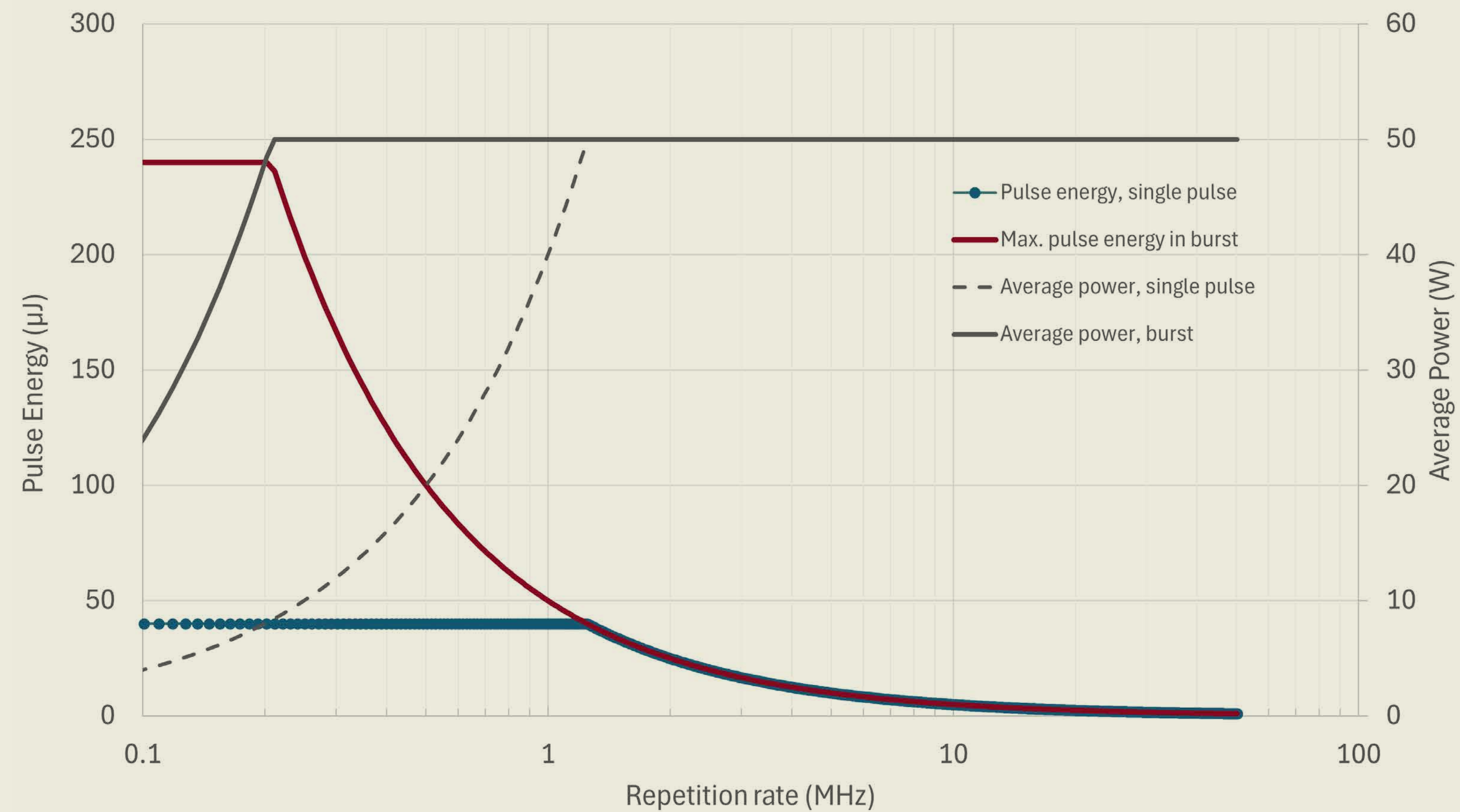

Features

Average power >50 W @1030 nm

Average pulse energy >40 µJ @1030 nm

Higher pulse energy available at <1 MHz

Tunable pulse widths <450 fs - 3 ps (shorter upon request)

Up to 50 MHz repetition rate

Excellent beam pointing stability

Programmable amplifier burst control

Based on world leading photonic crystal fiber technology

Designed for industrial reliability

Plug and Play

Maintenance-free 24/7 operation

Attachable second harmonic module

Average power 25 W @515 nm w/SHG

Average pulse energy >20 µJ @515 nm w/SHG

Specifications

aeroPULSE
FS50

Optical

		With dual wavelength module
Model	FS50	FS50-05
Center wavelength [nm]	1030 ± 5	515 ± 2
Power [W]	> 50	> 25
Pulse duration [fs]	< 450 - 3000	< 400
Pulse energy [μJ]	> 40 (up to 1.25 MHz)	> 20 (up to 1.25 MHz)
Repetition rate [MHz]	0 - 50	0 - 50
Analogue attenuator bandwidth [MHz]	< 2	< 2
Digital gate bandwidth [MHz]	< 2	< 2
Beam diameter [mm]	2.0 ± 0.5	2.0 ± 0.5
Spatial mode, fundamental	$M^2 \leq 1.3$	$M^2 \leq 1.3$
Beam asymmetry/ellipticity [%]	< 15	< 20
Power stability (50 hours), RMS [%]	< 0.5	< 1
Pointing stability (8 hours) [μrad]	< 50	< 50
Polarization - linear, PER [dB]	> 20	> 20

Specifications

aeroPULSE FS50

Electrical/Mechanical

With dual wavelength module

Model	FS50	FS50-05
Computer interface	USB 2.0/RS-232/Ethernet	USB 2.0/RS-232/Ethernet
Operation voltage [Hz]	100-240 VAC 50/60	100-240 VAC 50/60
Power consumption [W]	< 600	< 600
Operation temperature [°C]	15 - 35	15 - 35
Storage temperature [°C]	-20 - 60	-20 - 60
Laser head dimensions (LxHxW) [mm ³]	647.5 x 142 x 350	809.5 x 142 x 350
Laser head weight [kg]	35	39
Control unit dimensions (LxHxW) [mm ³]	442 x 168.5 x 374	442 x 168.5 x 374
Control unit weight [kg]	18.5	18.5
Umbilical length [m]	4	4
Chiller dimensions (LxHxW) [mm ³]	482 x 310 x 550	482 x 310 x 550
Chiller weight [kg]	40	40
Cooling	Water-based	Water-based

Technical Drawings

aeroPULSE
FS50

Laser head

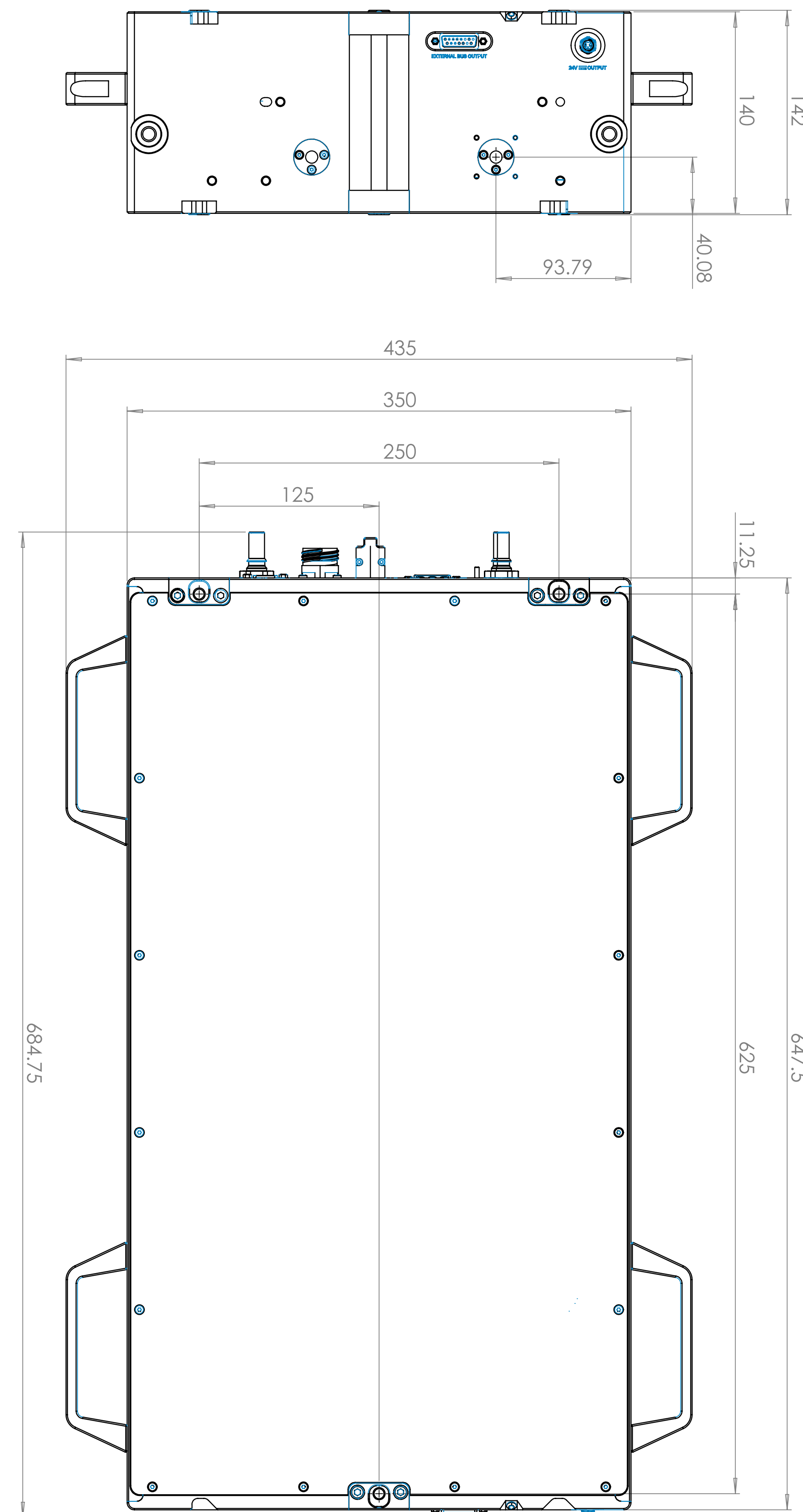

Laser head with SHG module

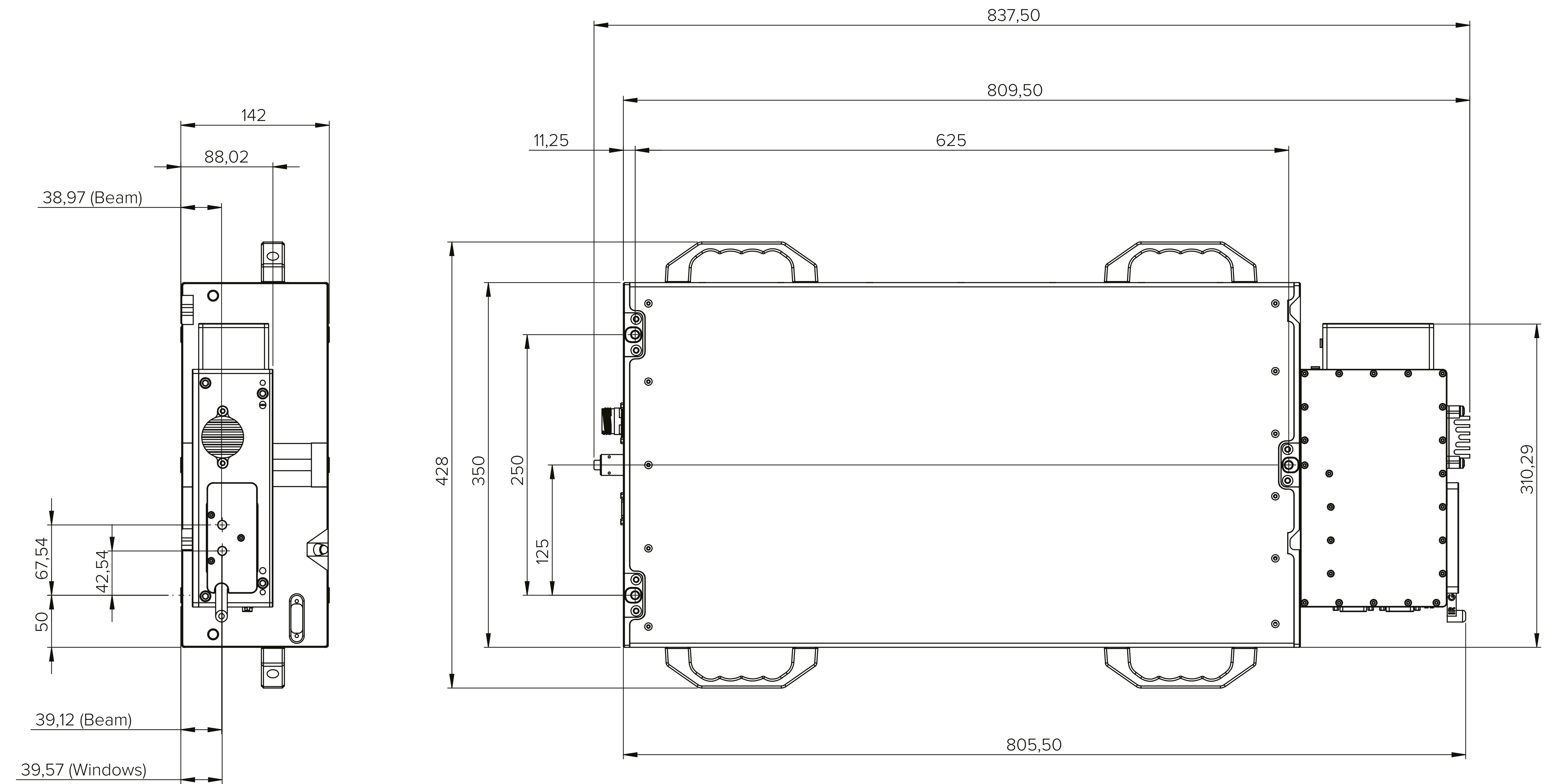

Technical Drawings

Controller

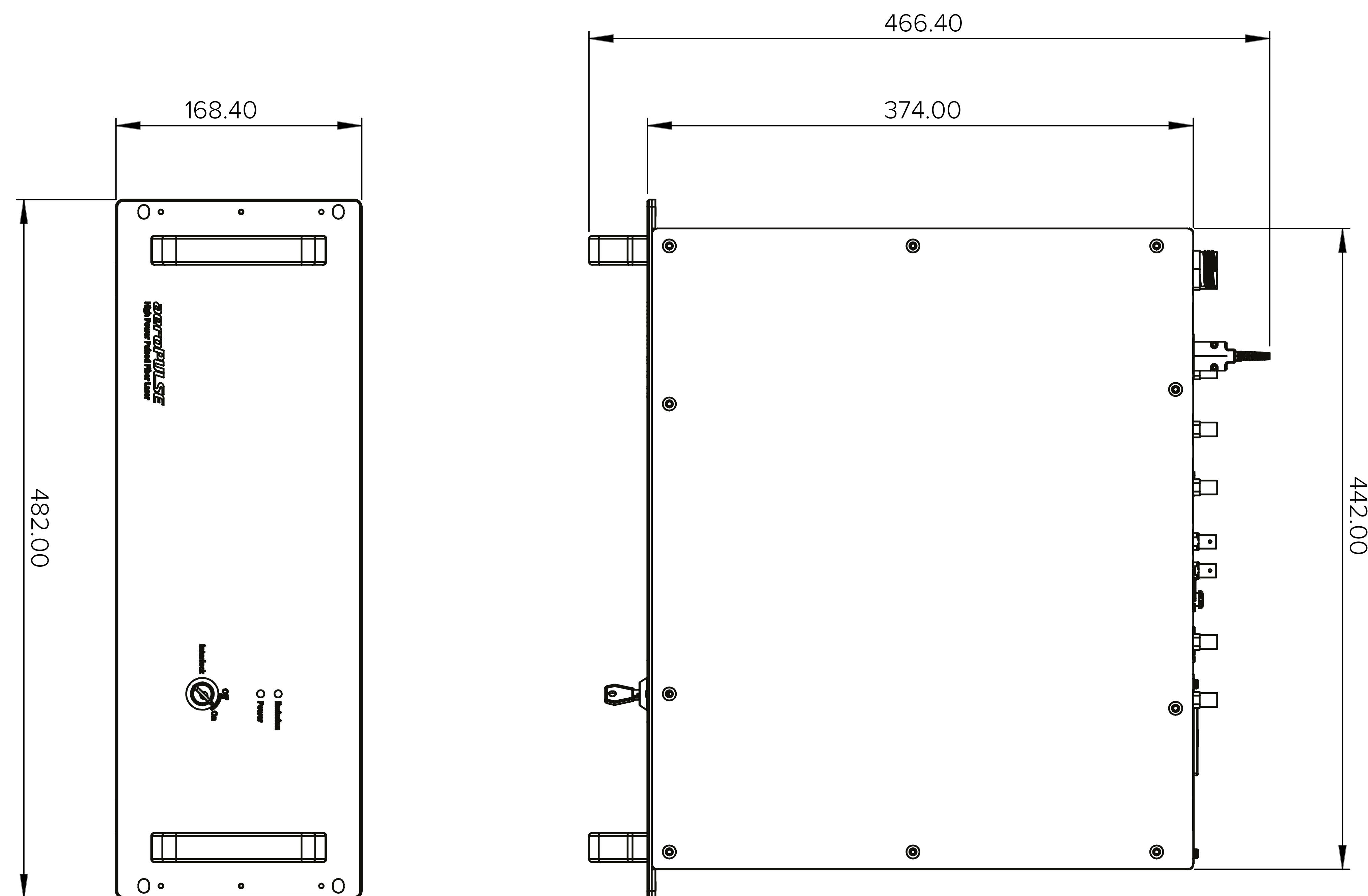

aeroPULSE FS50

All Hamamatsu Photonics A/S products are produced under our quality management system certified in accordance with the ISO 9001:2015 standard.

We're switching from NKT Photonics to Hamamatsu. Some documents and products still say NKT Photonics, others say Hamamatsu. The transition takes time, so please bear with us.

And rest assured, we're still the same people delivering the same high-quality fibers and lasers.



HAMAMATSU